

# COMROD AT100D/S

## 10 m Marine Transmitting Antenna

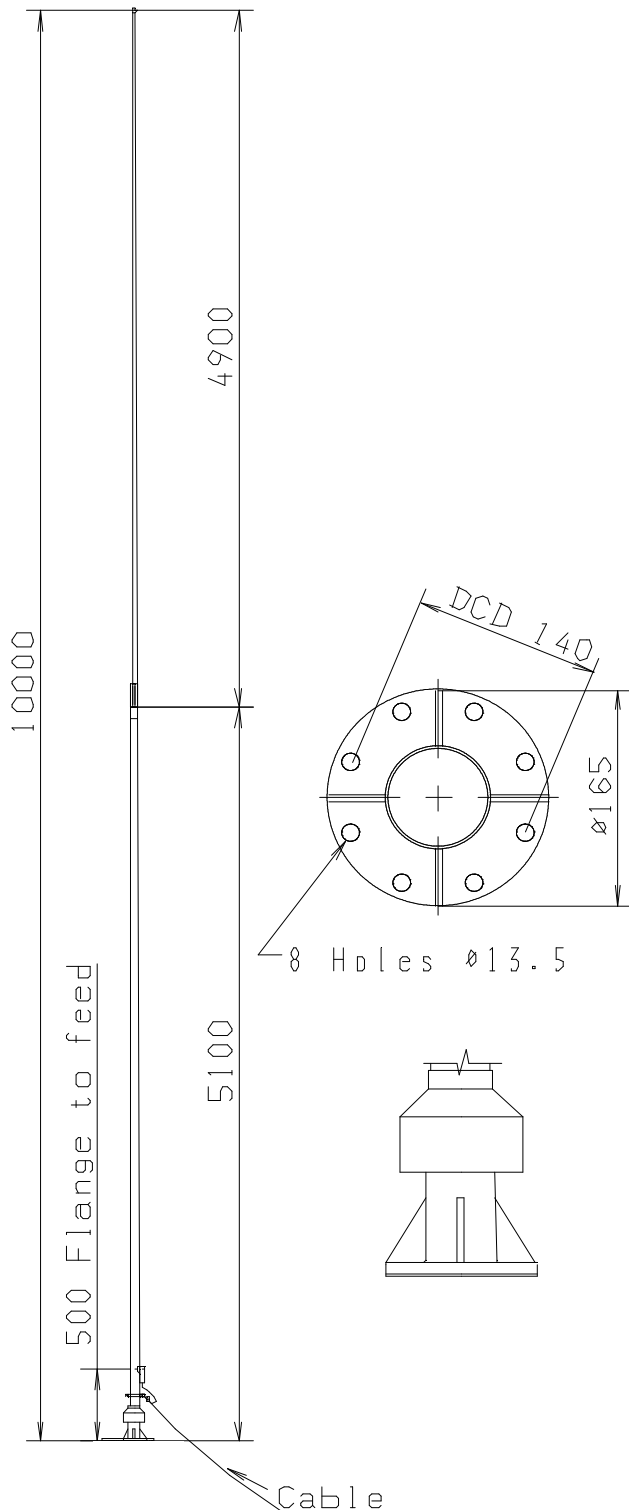

### Application:

AT100D/S is a high quality glassfibre transmitting antenna with side feed for marine coastal and HF telephony bands. It matches well all modern SSB marine telephony transmitters.

### Electrical specifications:

Frequency range	1.6-30 MHz
Power rating	1.5 kW PEP
Impedance	See diagram on reverse side
Pattern	Omnidirectional
Polarization	Vertical
Electrical length	10 m (33 ft)

### Mechanical specifications:

Design	Selfsupporting fiberglass rod with bronze flange.
Height	10 m (33 ft)
Weight	18.9 kg
Sections	Base section: ATB50D/S 16.3 kg Top section: APB50 2.6 kg
Wind rating	55 m/s = 125 mph
Moment of flexure	275 kpm at 55 m/s
Deflection due to wind load	5 m (16.7 ft) at tip ball at 55 m/s wind load
Finish	Polyurethane lacquer, white
Temperature range	-55 °C, +55 °C; -67 °F, +131 °F
Optional	End feed

### Mounting:

The AT100D/S is well suited for mounting on a pedestal or flange. We recommend the AG21 or AG26 lead through insulator, if the tuner is placed indoor.

The flange holes are matched to M12 bolts.

# Impedance at CF and HF

Frequency in MHz, normal installation

Frequency (MHz)	Impedance AT100D/S
1.6	5-j1000
2.0	6-j600
3.0	10-j350
4.0	11-j200
6.0	24-j34
7.0	48+j57
8.0	80+j140
9.0	180+j275
11.0	750+j60
12.0	500-j350
13.0	250-j360
14.0	150-j300
16.0	70-j180
17.0	55-j135
22.0	200+j130
23.0	350+j60
25.0	275-j200
30.0	68-j52.5

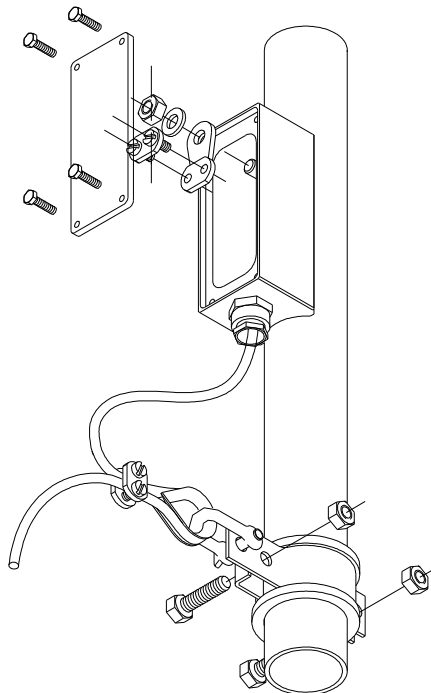

Installation of cable