

COMROD AT101D

10 m Marine Transmitting Antenna

Application:

AT101D is a high quality glassfibre transmitting antenna for marine coastal and HF telephony bands. It matches well all modern SSB marine telephony transmitters, four top whips gives it improved electrical characteristics.

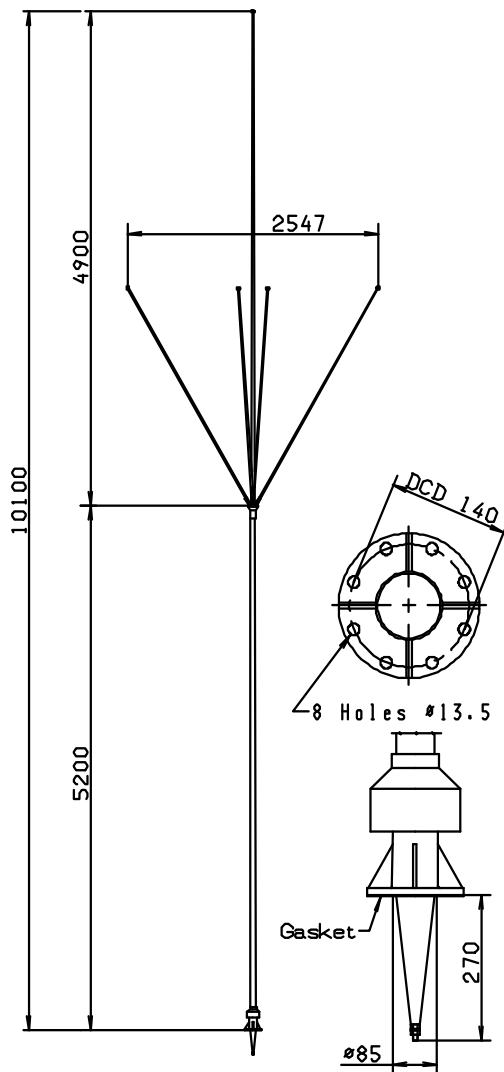

Electrical specifications:

Frequency range	1.6-30 MHz
Power rating	1.5 kW CW
Capacitance at CF	145 pF
Pattern	Omnidirectional
Polarization	Vertical
Electrical length	14.5 m (48 ft)

Mechanical specifications:

Design	Selfsupporting fiberglass rod with stainless steel armature and epoxy insulated feeding point
Height	10 m (33 ft)
Weight	23.1 kg
Sections	
Wind rating	55 m/s = 125 mph
Moment of flexure	400 kpm at 55 m/s
Deflection due to wind load	5.5 m (18 ft) at tip ball at 55 m/s wind load
Finish	Polyurethane lacquer, white
Temperature range	-55 °C, +55 °C; -67 °F, +131 °F

Mounting:

The AT101D is well suited for mounting on top of the radio cabin. If the feeding insulator is not long enough, extensions are available.

The flange holes are matched to M12 bolts.