

COMROD AT101D/S

10 m Marine Transmitting Antenna

Application:

AT101D/S is a high quality glassfibre transmitting antenna, with side feed for marine coastal and HF telephony bands. It matches well all modern SSB marine telephony transmitters, four top whips gives it improved electrical characteristics.

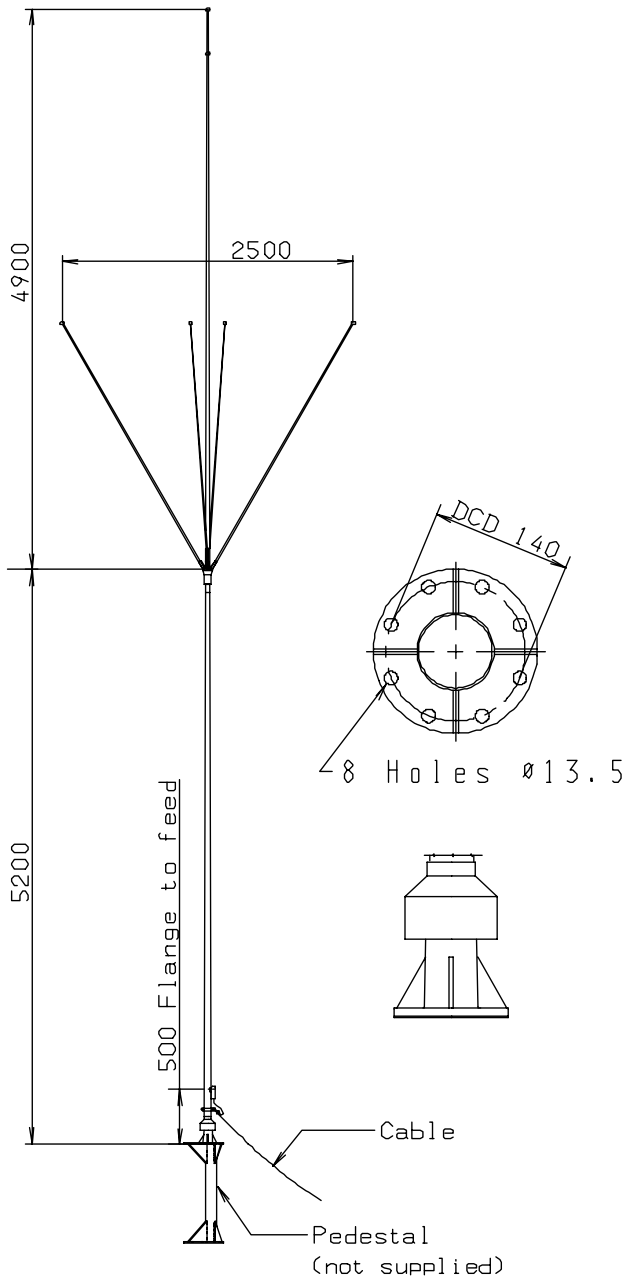

Electrical specifications:

Frequency range	1.6-30 MHz
Power rating	1.5 kW CW
Capacitance at CF	145 pF
Pattern	Omnidirectional
Polarization	Vertical
Electrical length	14.5 m (48 ft)

Mechanical specifications:

Design	Selfsupporting fiberglass rod with bronze flange.	
Height	10 m (33 ft)	
Weight	23.1 kg	
Sections	Base section: ATB51S	17.0 kg
	Top section: APB50	2.6 kg
	Top whips: 4xAPB3	3.8 kg
Wind rating	55 m/s = 125 mph	
Moment of flexure	400 kpm at 55 m/s	
Deflection due to wind load	5.5 m (18 ft) at tip ball at 55 m/s wind load	
Finish	Polyurethane lacquer, white	
Temperature range	-55 °C, +55 °C; -67 °F, +131 °F	

Mounting:

The AT101D/S is well suited for mounting on a pedestal or flange. We recommend the AG21 or AG26 lead through insulator, if the tuner is placed indoor.

The flange holes are matched to M12 bolts. For more detailed mounting instructions, see installation drawing no. 06-6-007.