

# COMROD AT53TS16-2

## 16' Marine HF Antenna

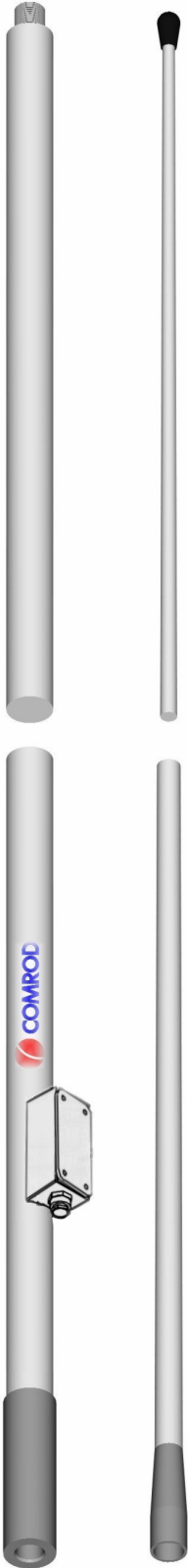

### Application:

AT53TS16-2 is a high quality fiberglass HF antenna for marine coastal and SSB telephony bands. It is designed for use on smaller craft, but the high quality means it may be used on all kinds of vessels. The antenna is side fed, and the bottom bracket does not need to be insulated.

It withstands the rapid movements that may be the result of use on small - high speed craft.

### Electrical specifications:

Frequency range	1.6-30 MHz
Power rating	1 kW PEP
Static capacitance	50 pF @ 2MHz
Polarization	Vertical
Radiation pattern	Omnidirectional
Electrical length	(4.6 m.) 15.1 ft.
Feed system	Open wire, side fed

### Mechanical specifications:

Design	Fiberglass whip in two sections.
Height	16' (4.9 m)
Weight	3.5 kg
Sections	Base: 8 ft. (2.45 m.) Top whip: 8 ft. (2.45 m.)
Wind rating	55 m/s = 125 mph
Moment of flexure	40 kpm at 55 m/s
Deflection due to wind load	3 m (10 ft) at tip ball with 55 m/s wind load
Finish	Polyurethane lacquer, white or other colors on request Chrome plated fittings
Temperature range	-55 °C, +71 °C, -67 °F, +160 °F
Ice build-up	Not affected

### Mounting:

The antenna is mounted at the superstructure with a UNS1"x14 base, and a 1½" support at least 0.5m above the base. Support and base not included. These dimensions means that all standard mounting accessories can be used.

Different versions:



AT53M16-2  
Mast mount,  
self supporting.



AT53DS16-2  
Deck mount,  
self supporting.



AT53TS16-2  
Stand off mount.

**Mounting:**

AT53DS16-2 is easily mounted to the bulkhead by means of 4 holes in the aluminum bracket, or to a mast or tube with U-bolts. The U-bolts in stainless steel, are included.

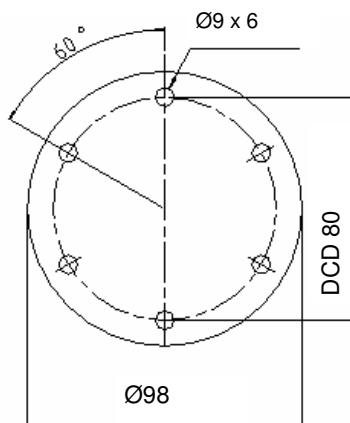

**Mounting:**

To be mounted at superstructure with UNS 1x14 base and support approx. 1.5' up. Stand off support and base are not included.