

INTAS – S2

Two radios – one antenna

Our task is the operation of as many radios as possible with a minimum number of antennas. The ideal solution would be to reduce the number of required antennas to one per frequency band. This solution is technical not feasible, as proper functioning of the individual radios could then no longer be ensured under all conceivable operating conditions. The consequence would be a mutual frequency band “clog up” of the individual sets.

Comrod has therefore developed an almost optimum solution to this problem.

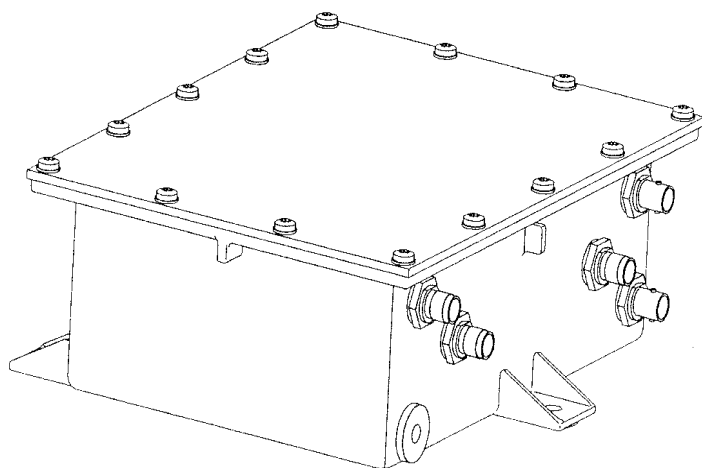

The intelligent antenna system is designed to permit optimum employment of existing antennas while minimizing the number required and simultaneously ensuring all system requirements are met. As a result of this reduction in the number of antennas – without any constraints on system characteristics new approaches have been developed to increase the overall transmitting quality of the system both through an increase average range and through appropriate communications procedures.

An emergency loop-trough is available for connecting any radio directly to the antenna.

Technical data.	
Frequency Range	20..120 MHz
Channel Spacing	Any spacing (equipment defined)
Radio bit rate	Any rate (Equipment defined)
Transmitting power	2 * 100W maximum
Insertion loss	Less than 3.8dB through multicoupler Less than 0.1dB trough emergency loop
Impedance	HF inputs: 50 Ohm HF outputs: 50 Ohm
Interoperability	Operation with radio system within a frequency range of 20..120 MHz.
EMC	Per MIL STD 462
NEMP	Per AEP4/STANAG 4145
Environmental	Per MIL STD810/DIN 58390
Operating temperature range:	-35 C... +63 C Other temperatures ranges are available.
Dimensions	Approx. 220 x 200 x 80 mm
Weight	Approx 2 kg.
Connectors	BNC female, or customer specified

The system reduces the number of antennas on the vehicle, this has a beneficial effect on the radiation pattern as can be seen below:

NEC model of vehicle

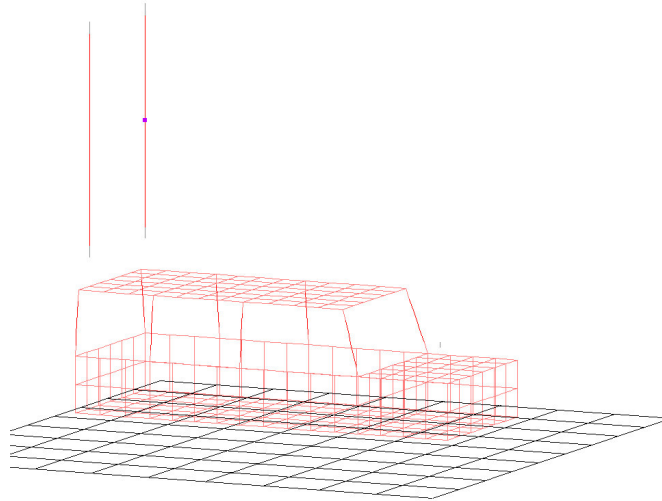

With INTAS

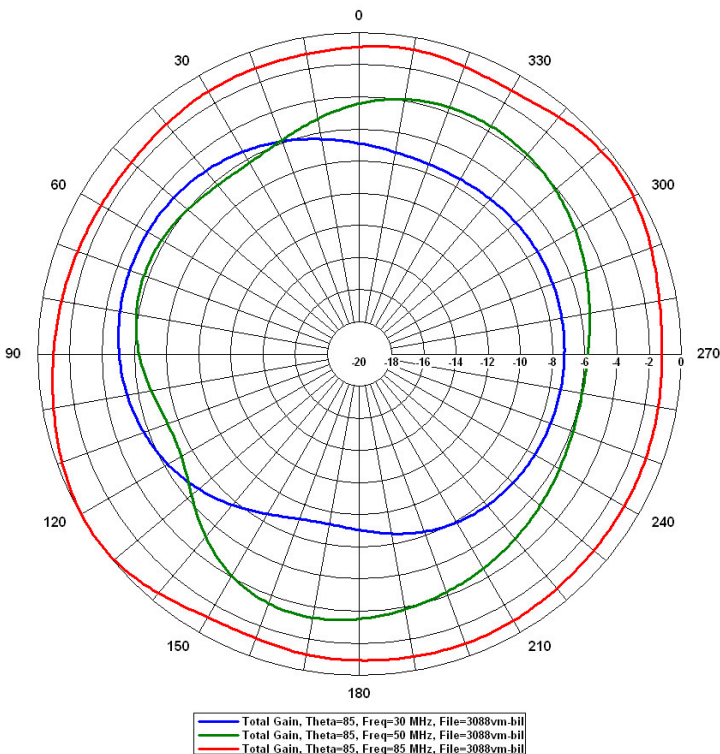

With two separate antennas

