

OVERVIEW

- Heavy duty aluminium telescopic mast capable of supporting heavy top loads
- Heights up to 30 metres (98 ft)
- Top loads up to 117kg (257 lbs) *
- Hand cranked manual winch or optional electrically driven winch
- Mast rotation to enable azimuth top load pointing
- Manufactured from lightweight hexagonal aluminium tubes
- Easily installed by two people
- Top interface can be adapted to suit the client top load
- Suitable for elevating antennas, sensors, optronic equipment etc
- All metal parts are plated or painted aluminium or stainless steel
- Thousands of masts in-service worldwide
- Meets MIL-STD-810F environmental standard for operation in extreme conditions

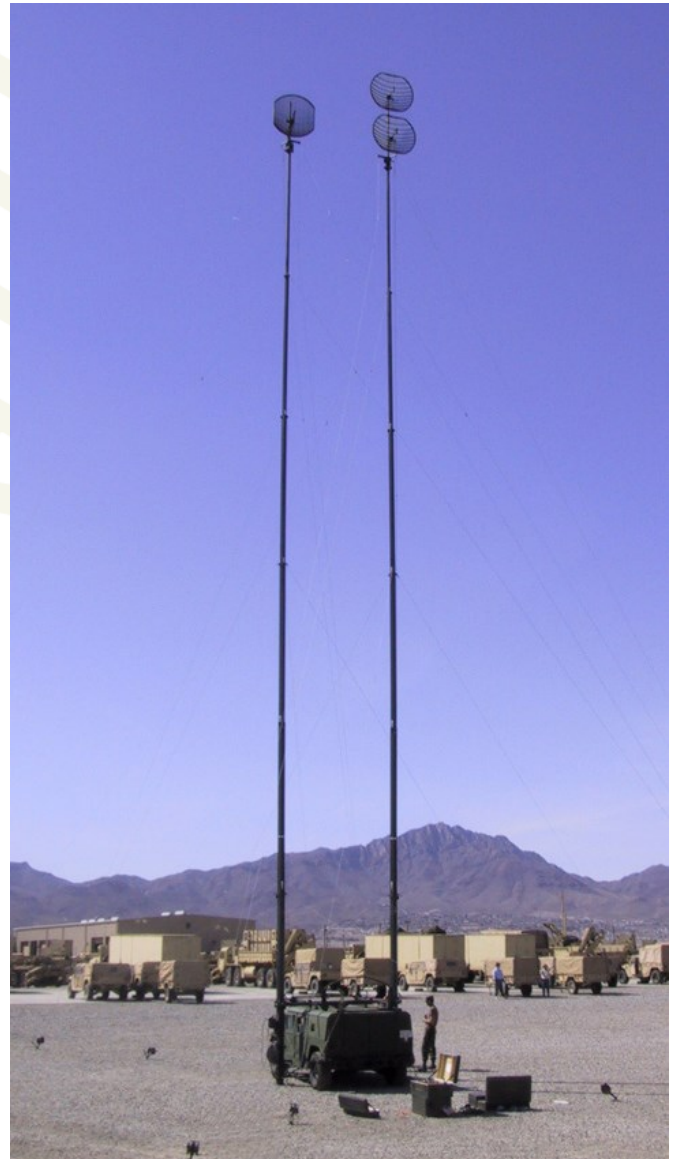

MAST TYPE	TM 210/30-5.9
Elevated Height	30m (98ft)
Retracted Height	5.9m (19ft)
Max Top load *	117kg
Max. Headload Area *	2 x 0.7m ² (2 x 7.5ft ²)
Number of Sections	6
Number of Stays / Levels	3 x 4
Guy Radius	15/16/17m (49/52.5/56ft)
Maximum WindSpeed	33m/s (74mph)
Headload Attachment	Ø66mm
Mast Weight	220kg (484lbs)
Accessories Weight	120kg (264lbs)

* Typical values shown. Actual values will be subject to a combination of top load weight, top load area and pointing accuracy required.



The hexagonal sections move inside each other on plastic guideways which provide the masts with excellent stability and torsional resistance.

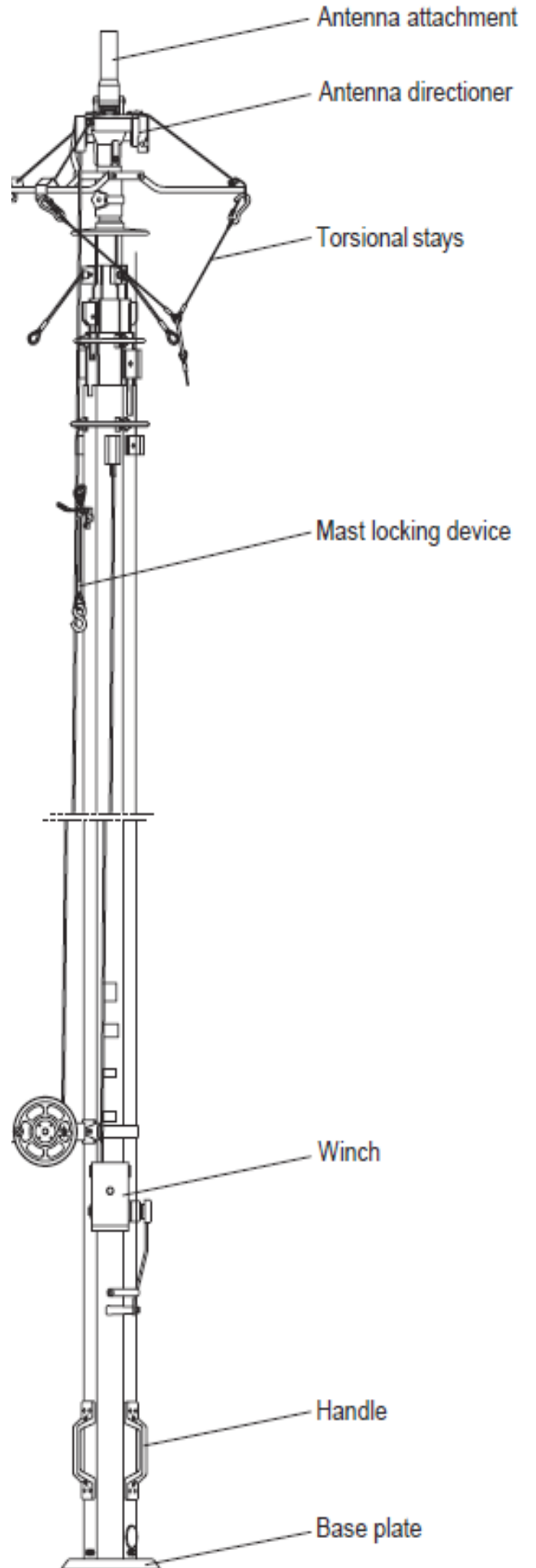
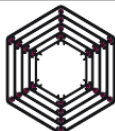

OPTIONS

Vehicle and Shelter Mounting Brackets

Comrod has a wide range of brackets for mounting heavy duty series aluminium masts onto vehicles, shelters and buildings. Please contact Comrod to discuss your specific requirement.

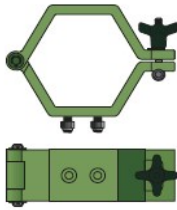

Fixed brackets

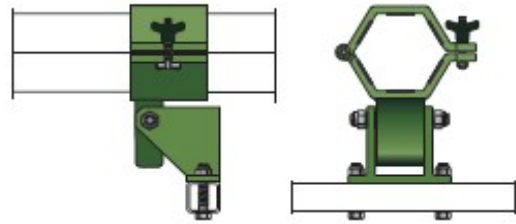

Hinged brackets



PAM (Pull-out Assist Mechanism)

PAM brackets support the full weight of the mast during deployment from a vehicle or shelter. The PAM main components are an inner and outer square tube, friction clutch and clamp for holding the mast. The outer square tube is used to mount the assembly to the shelter wall of the roof of the transport vehicle. The inner square tube is connected to the mast clamp by a spring loaded friction clutch and is extended or retracted by means of roller wheels.

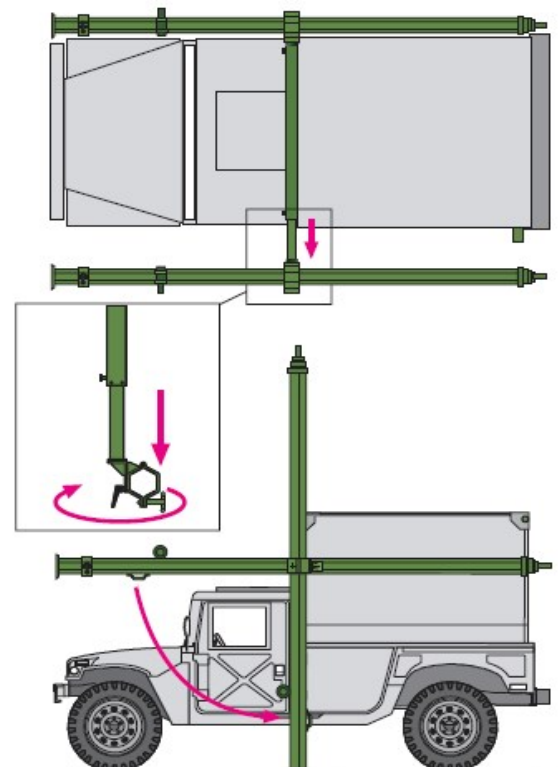

PAM (Pull-out Assist Mechanism) - Continued



Mast in transport position



Mast weight fully supported during deployment

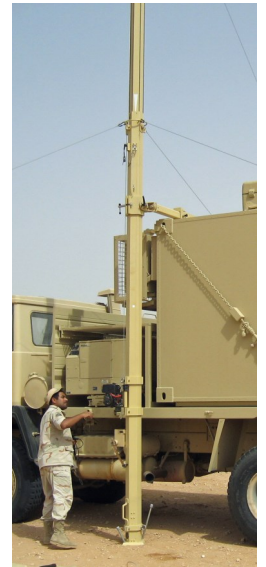

Mast fully deployed

Top Load Accessories and Ancillaries

Comrod has a wide range of top load accessories to compliment the lightweight series aluminium masts. Accessories are available such as antennas directioners, rotators, tilters, dual rotator/tilters, extension tubes. Rotators and tilters can be operated manually using ropes or can be motor driven. Please contact Comrod to discuss your specific requirement.



Directioners
(Rotator/Tilter)



Tilters

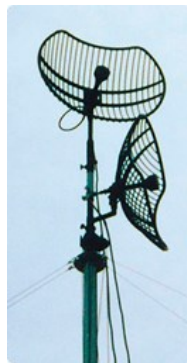

Single and Dual
Rotators



Mounting Bars



Headload
Adaptors