

# COMROD HF1630/ 4-5m

## HF Mobile Whip

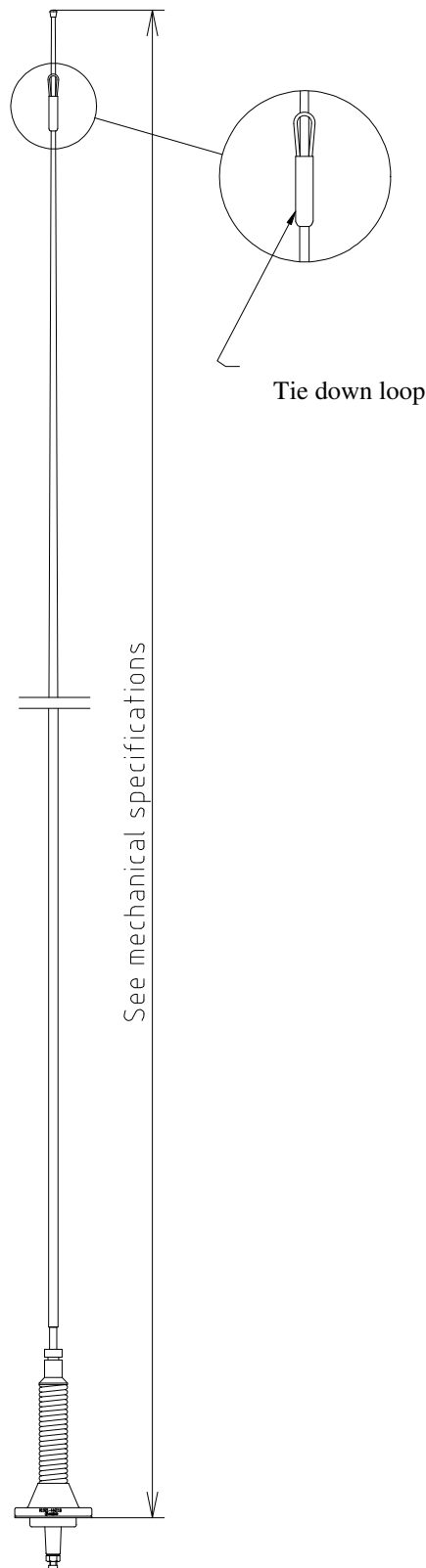

### Application:

The HF1630m is designed for land mobile services in the HF-band 1,6 - 30 MHz. It consists of a fiberglass whip, and a base section. The whip is intended to be fixed in a deflected position when the vehicle is moving. The whip is easily removed by hand, and a wire antenna can be attached to the base. A tie down loop eases fixing a rope when the antenna is deflected.

### Electrical specifications:

Frequency range	1.6 - 30 MHz
Impedance	Depending on mounting, example overleaf
Power rating	400 W CW
Radiation pattern	Omnidirectional
Electrical length	HF1630/5 = 5 m HF1630/4 = 4 m
Polarization	Vertical
High voltage protection	16KV @ 50Hz

### Mechanical specifications:

Design	End fed whip. Radiating element completely enclosed in epoxy/fibreglass laminate. Metal parts are brass or stainless steel.
Length, mounted	HF1630/5 = 5.1 m HF1630/4 = 4.1m
Weight	5m = 4.3 kg 4m = 4 kg
Wind rating	55 m/s = 125 mph
Finish	Polyurethane lacquer, olive drab.
Temperature range	-55 °C, +71 °C; -67 °F, +160 °F

### Mounting:

The base uses the Nato standard 4 hole pattern.

Nato codification complete antenna (5m)	5985-25-144-8681
-----------------------------------------	------------------

Base:

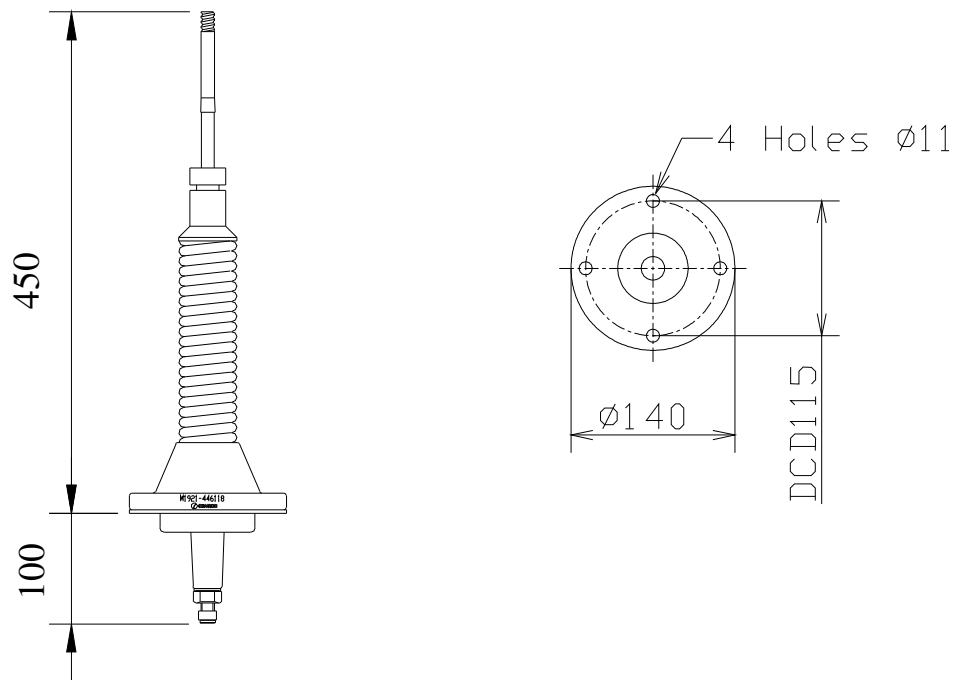

Impedance:

Frequency (MHz)	Impedance HF1630/5m *
2.0	5.3-j1427
4.0	6.2-j763
6.0	7.8-505
8.0	10-j348
10.0	14-j236
12.0	20-j143
14.0	28-j60
16.0	41+j22
18.0	60+j110
20.0	92+j214
22.0	144-j333
26.0	478-j686
30.0	1829-j137

\* Calculated for a ground resistance of 5Ω

Complete antenna / Parts:

Article number	NATO codification	Description
<b>042630</b>	<b>5985-25-144-8681</b>	<b>Complete antenna whip</b>
042602	5985-25-125-8824	Base
042635	5985-25-144-8682	Whip section, 4,7m